

Name \_\_\_\_\_ Date \_\_\_\_\_ Period \_\_\_\_\_

**Worksheet 5.2—Applications of Angles**

Show all work on a separate sheet of paper. All answers must be given as either simplified, exact answers. A calculator is **permitted** unless otherwise stated. Unless stated otherwise, report all non-exact answers to 3 decimal places

**Multiple Choice**

- If the perimeter of a pizza slice is 4 times its radius, then the radian measure of the central angle of the slice is  
 (A) 2      (B) 4      (C)  $\frac{2}{\pi}$       (D)  $\frac{4}{\pi}$       (E) Not enough information
- A bicycle with 26-inch diameter wheels is traveling at 10 mph. to the nearest whole number, how many revolutions does each wheel make per minute?  
 (A) 54      (B) 129      (C) 259      (D) 406      (E) 646
- One revolution per minute is about:  
 (A) 0.0524 rad/s      (B) 0.105 rad/s      (C) 0.95 rad/s      (D) 1.57 rad/s      (E) 6.28 rad/s
- If a wheel turns with constant angular velocity then:  
 (A) each point on the wheel moves with the same linear velocity  
 (B) the velocity of each point decreases as the radius increases.  
 (C) the wheel turns through equal angles in equal times  
 (D) the angle through which the wheel turns in each second increases as time goes on  
 (E) the angle through which the wheel turns in each second decreases as time goes on
- If a wheel turning at a constant rate completes 100 revolutions in 10 s its angular speed is:  
 (A) 0.31 rad/s      (B) 0.63 rad/s      (C) 10 rad/s      (D) 31 rad/s      (E) 63 rad/s
- The angular speed in rad/s of the minute hand of a watch is:  
 (A)  $60/\pi$       (B)  $1800/\pi$       (C)  $\pi$       (D)  $\pi/1800$       (E)  $\pi/60$
- A ventilation fan has blades of 0.25 m in radius rotating at 20 rpm. What is the approximate linear speed of each blade tip?  
 (A) 0.02 m/s      (B) 0.25 m/s      (C) 0.52 m/s      (D) 5.0 m/s      (E) 20 m/s
- A lawn roller pulled by a tractor with a 9-inch radius makes 0.9 revolutions per second. Find the angular speed of the roller in radians per second.  
 (A) 1.8      (B)  $1.8\pi$       (C) 0.03      (D) 8.1      (E) 50.893
- The same lawn roller from above is now being pushed faster so that it makes 1.4 revolutions per second. Find the speed, in **miles per hour**, of the tractor that is pulling the roller. There are 5280 ft in one mile.  
 (A) 79.168      (B) 2.821      (C) 0.047      (D) 4.498      (E) 1.432
- Given that the radius of a circle is 5 ft, what is the area of a sector of that circle, in square feet, whose central angle is  $60^\circ$ ?  
 (A) 2.617      (B) 13.089      (C) 26.179      (D) 750      (E) 42971.834

**Short Answer:**

11. A boy rotates a stone in a 3-ft-long sling at the rate of 15 revolutions every 10 seconds. Find the angular and linear velocities of the stone in radians per second and feet per second respectively.
12. Each tire on a vehicle has a radius of 22 inches. The tires are rotating at 550 RPMs. Find the speed of the vehicle in miles per hour.
13. The second hand of a clock is 12.9 inches long.
  - (a) Find the linear speed of the tip of the second hand, in inches per second.
  - (b) Through how much area of the clock has the second hand travelled through after 32 seconds?



14. Find the angle in decimal degrees that describes the following compass bearings. Refer to the Compass Rose at right.
  - (a) ESE    (b) NNE    (c) WSW
  - (d) SbW    (e) NWbW

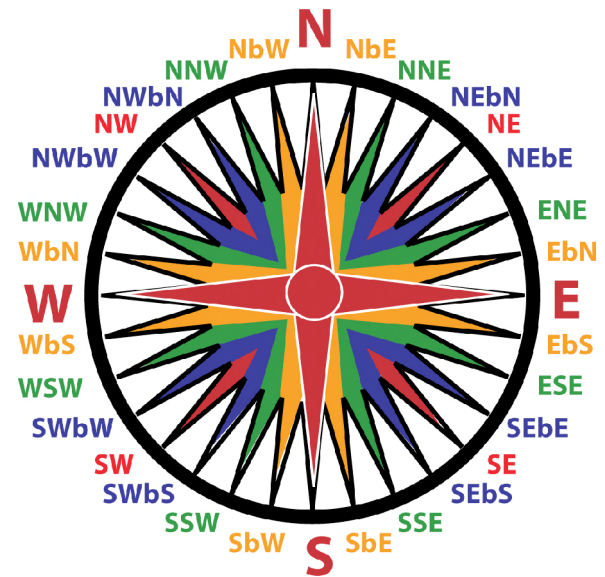

15. A **nautical mile** (naut mile) is the length of 1 minute of arc along the Earth's equator. A central angle of Earth that measures  $1/60$  of a degree (1 minute) intercepts an arc along the surface of the Earth that is 1 naut mile long. The arc length formula allows us to convert between nautical miles and **statute miles** (stat mile), the familiar "land mile" of 5280 feet.
  - (a) Using the arc length formula and the fact that the radius of the Earth is roughly 3960 statute miles, determine the length of a nautical mile in statute miles.
  - (b) If a boat is traveling at 35 **knots** (nautical miles per hour), how fast is it going in mph?
  - (c) Two boats leave the same port at the same time at the same speed of 35 knots but in different directions. I one boat travels on a bearing of  $60^{\circ}13'11''$  and the other on a bearing of  $63^{\circ}5''$ , approximately how far apart are they from each other when they are both 20 nautical miles from the port?

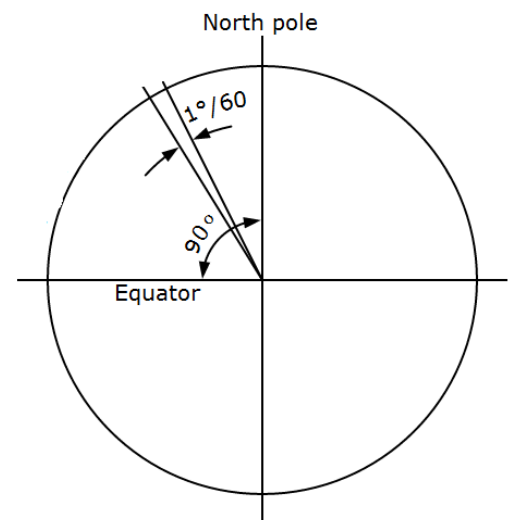

16. The top and bottom ends of a windshield wiper blade are 34 in. and 14 in. from the pivot point, respectively (shown at right). While in operation, the wiper sweeps through an angle of  $135^\circ$ . Find the area swept by the blade.

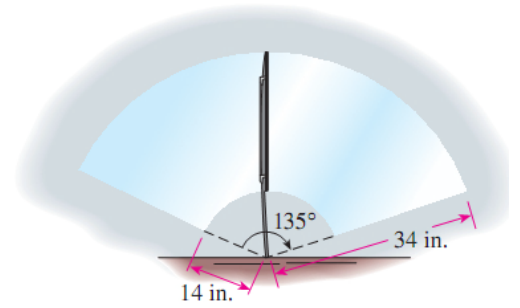

17. The sprockets and chain of a bicycle are shown in the figure below. The pedal sprocket has a radius of 4 in., the wheel sprocket has a radius of 2 in., and the wheel has a radius of 13 in. If the cyclist pedals at 40 RPM,

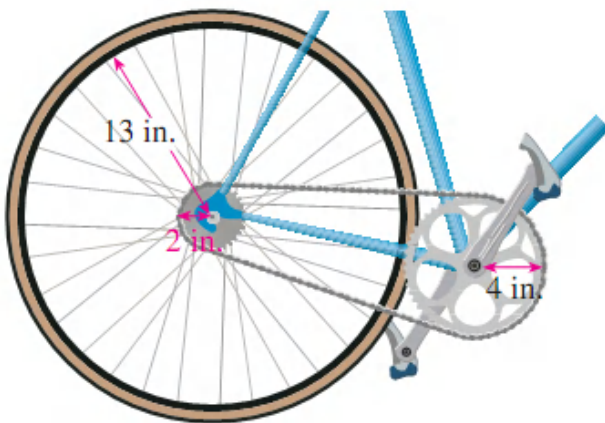

- (a) find the angular speed of the wheel sprocket.  
 (b) find the speed of the bicycle in mph.

18. It takes ten identical pieces to form a circular track for a pair of toy racing cars. If the inside arc of each piece is 3.4 inches shorter than the outside arc, what is the width of the track?