

Name \_\_\_\_\_ Date \_\_\_\_\_ Period \_\_\_\_\_

**Worksheet 9.1—Conic Sections: Circles**

Show all work. No calculator is permitted, unless explicitly stated.

**Multiple Choice**

\_\_\_\_\_ 1. What is the standard equation of a circle with a center of (7,0) and radius of 3?

(A)  $(x - 7)^2 + y^2 = 9$

(B)  $x^2 + (y - 7)^2 = 9$

(C)  $(x - 7)^2 + y^2 = 3$

(D)  $x^2 + (y - 7)^2 = 3$

\_\_\_\_\_ 2. What are the coordinates of the center and the radius of the circle whose standard equation is  $(x - 4)^2 + (y - 3)^2 = 25$ 

(A) Center (4,3),  $r = 5$

(B) Center (4,3),  $r = 25$

(C) Center (-4, -3),  $r = 25$

(D) Center (-4, -3),  $r = 5$

\_\_\_\_\_ 3. What is the standard equation for the circle whose center is the origin and whose radius is 4?

(A)  $x^2 + y^2 = 4$

(B)  $x^2 - y^2 = 4$

(C)  $x^2 + y^2 = 16$

(D)  $x^2 - y^2 = 16$

\_\_\_\_\_ 4. What is the center and radius for the circle whose general equation is  $8x + x^2 - 2y = 64 - y^2$ ?

(A) Center (4,1),  $r = 9$

(B) Center (-4,1),  $r = 9$

(C) Center (1, -4),  $r = 81$

(D) Center (-4,1),  $r = 81$

\_\_\_\_\_ 5. What is the center for the circle whose general equation is  $4x - 36 + y^2 = -x^2 - 6y$ ?

(A) (-2,5)

(B) (2,3)

(C) (2, -5)

(D) (-2, -3)

6. Graph the following equation:  $x^2 - 10x + y^2 = -9$ .

(A)

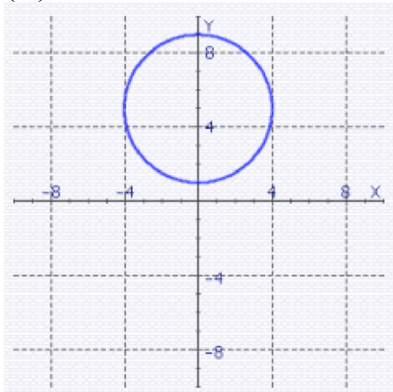

(B)

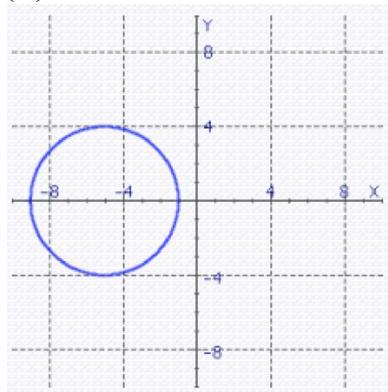

(C)

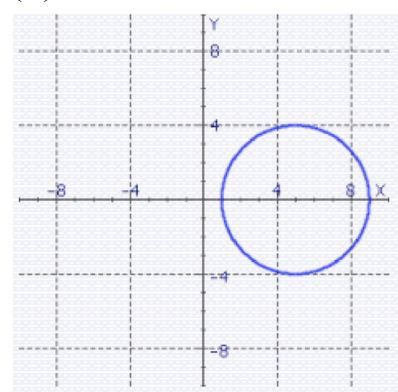

7. Which of the following graphs represents the equation  $3x^2 - 75 = -3y^2$ ?

(A)

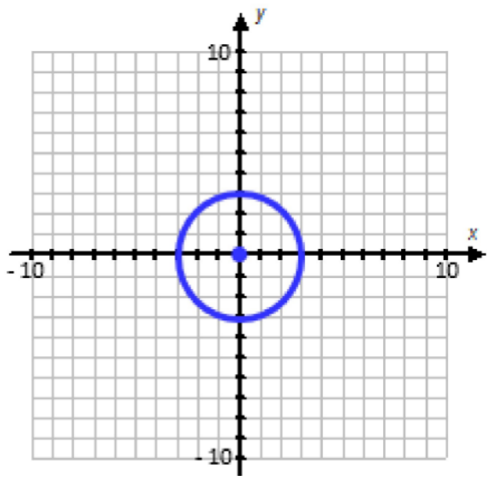

(B)

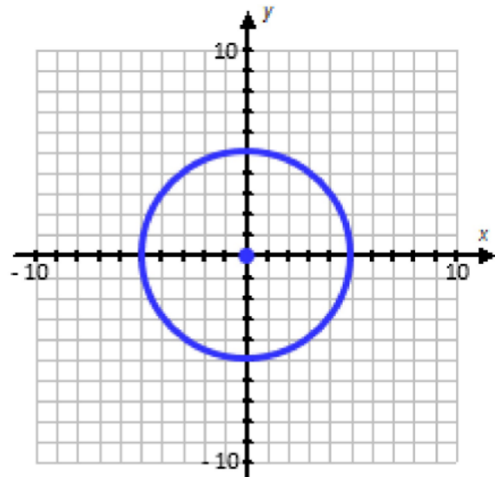

(C)

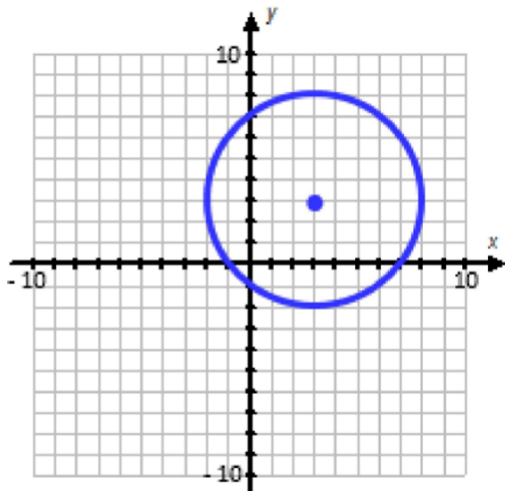

(D)

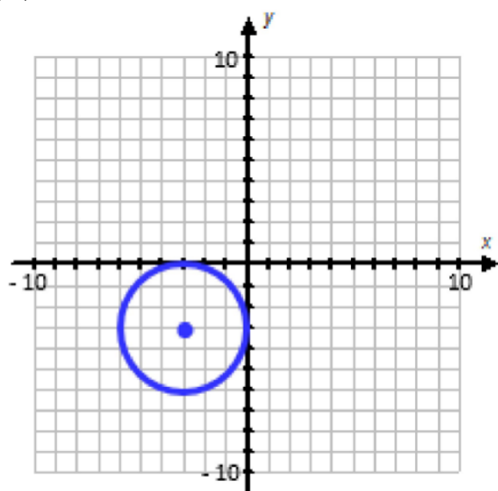

8. If the line segment  $\overline{AB}$  on the given graph at right represents the diameter of a circle, what is the equation of the circle?

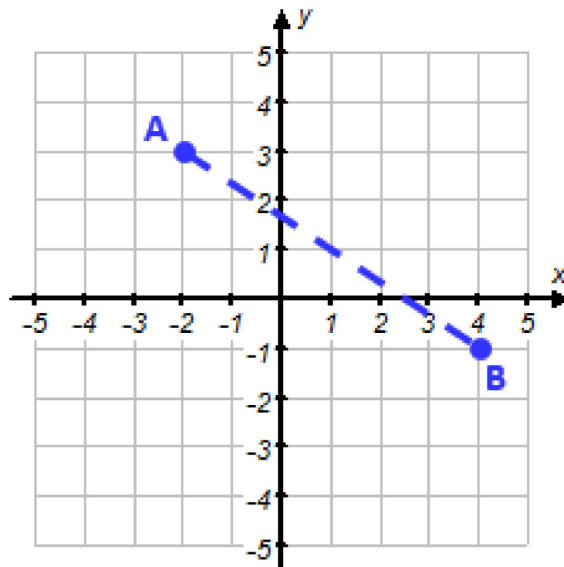

- (A)  $(x + 1)^2 + (y + 1)^2 = \sqrt{52}$
- (B)  $(x + 1)^2 + (y + 1)^2 = 169$
- (C)  $(x - 1)^2 + (y - 1)^2 = 52$
- (D)  $(x - 1)^2 + (y - 1)^2 = 13$

9. What is the graph of the circle whose general equation is  $x^2 + y^2 - 6y - 4x = -4$ ?

(A)

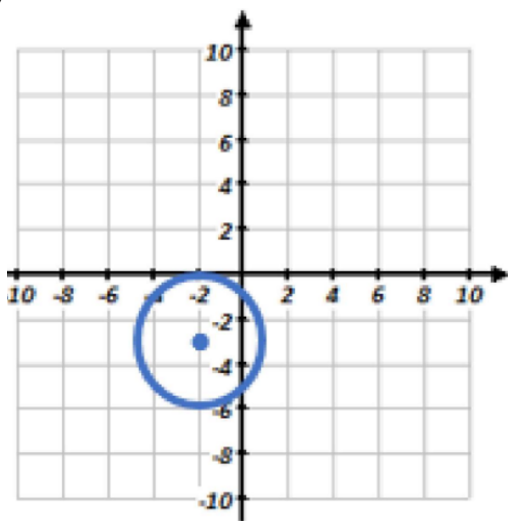

(B)

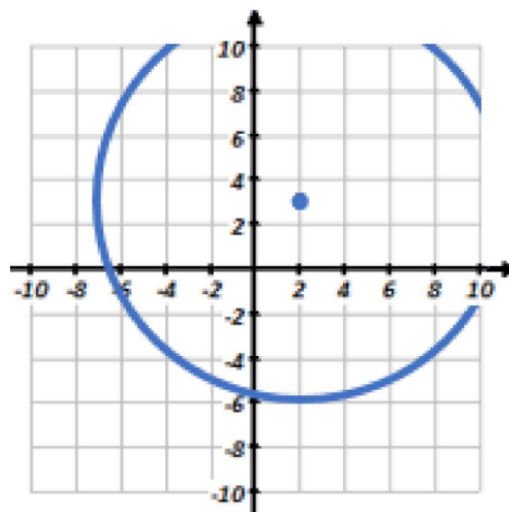

(C)

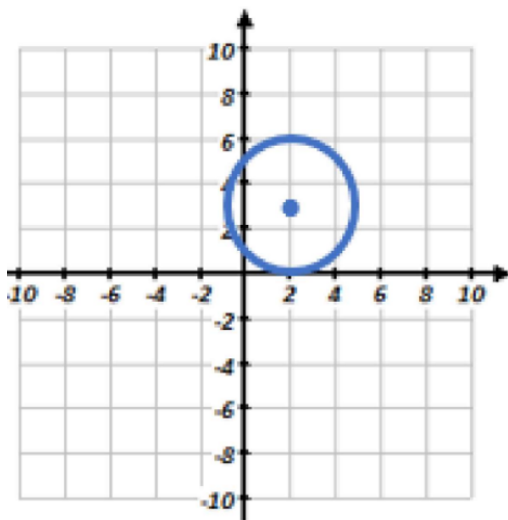

(D)

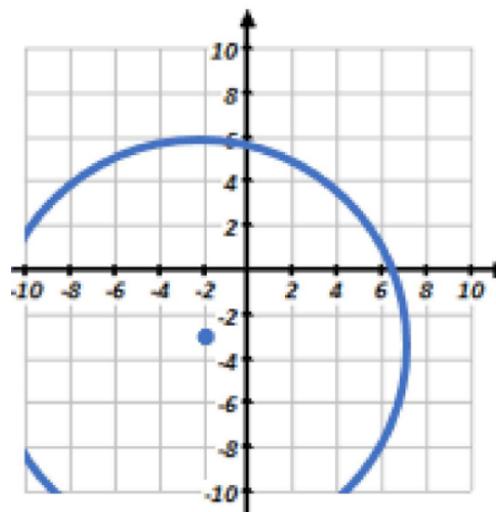

10. Phoenix County in Georgia is a small county and only has the funds to build one fire station. Ideally, a fire station should be within 5 miles of the city it supports.

Which equation below helps to validate the best place to put a fire station because it shows the 5-mile perimeter encapsulating the most cities possible?

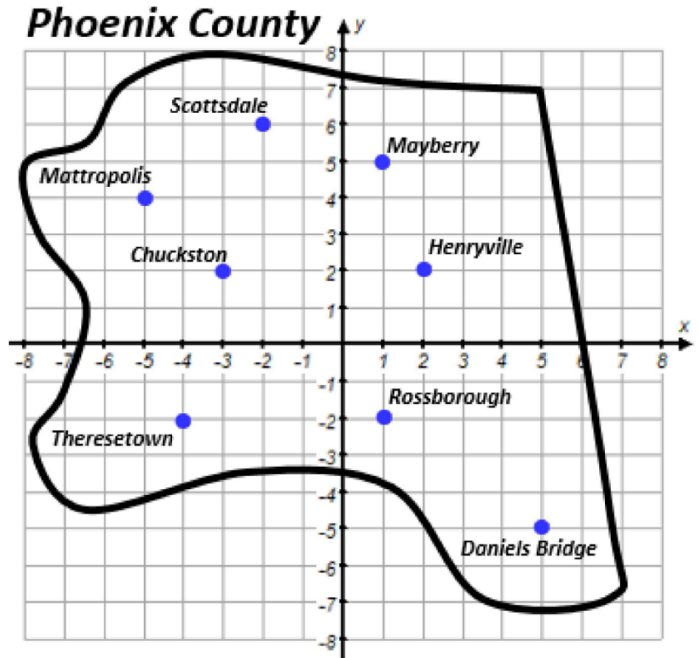

- (A)  $(x - 2)^2 + (y + 2)^2 = 25$
- (B)  $(x + 1)^2 + (y - 2)^2 = 25$
- (C)  $(x + 3)^2 + (y + 1)^2 = 25$
- (D)  $(x - 1)^2 + (y + 2)^2 = 25$

11. A skee-ball gaming machine is to be created using a fabrication machine that requires the equation of each circle to be cut out of the based platform (the gray circles where the ball falls through).

Which is the only equation below that does **NOT** correctly describe one of the holes that needs to be cut out?

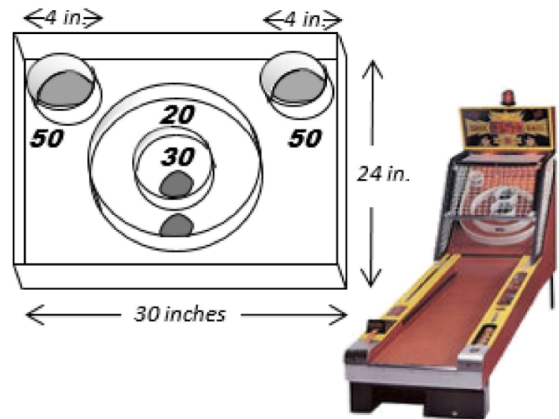

(A top-down view is shown below and laid out on a coordinate grid.)

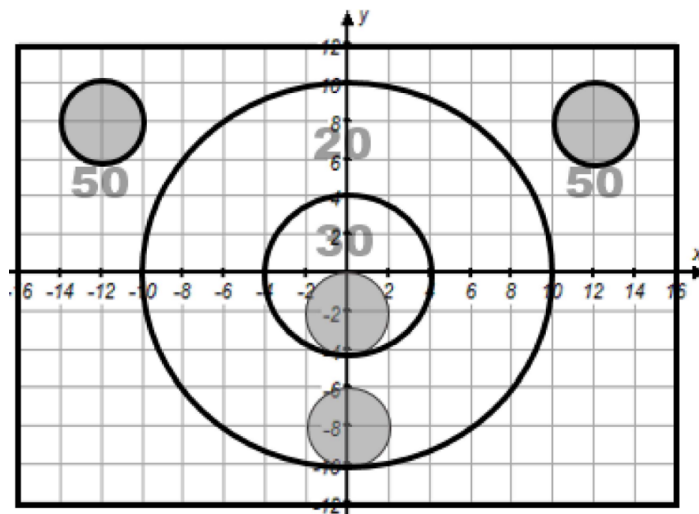

- (A)  $(x - 12)^2 + (y - 8)^2 = 4$
- (B)  $(x + 12)^2 + (y - 8)^2 = 4$
- (C)  $(x + 2)^2 + y^2 = 4$
- (D)  $x^2 + (y + 2)^2 = 4$

\_\_\_\_\_ 12. Find the general equation of the circle whose center is (2,5) and radius of 5.

(A)  $x^2 + y^2 + 4x - 10y + 4 = 0$

(B)  $x^2 + y^2 - 4x - 10y + 4 = 0$

(C)  $x^2 + y^2 + 4x + 10y + 4 = 0$

(D)  $x^2 + y^2 + 4x - 10y - 4 = 0$

\_\_\_\_\_ 13. Find the general equation of a circle which passes through the points (5,9) & (2,5).

(A)  $x^2 + y^2 + 4x - 10y + 4 = 0$

(B)  $x^2 + y^2 - 4x - 10y + 4 = 0$

(C)  $x^2 + y^2 + 4x + 10y + 4 = 0$

(D)  $x^2 + y^2 + 4x - 10y - 4 = 0$

\_\_\_\_\_ 14. If a circle passes through the points (4,0) & (0,2), and the center is on the y-axis, find the radius of the circle.

(A) 25

(B) 20

(C) 5

(D) 5

(E) 10

\_\_\_\_\_ 15. The point (6,2) lies \_\_\_\_\_ the circle  $x^2 + y^2 - 2x - 4y - 36 = 0$ .

(A) inside

(C) outside

(D) on

(E) none of these

**Short Answer**

16. For each of the following, write the standard equation of the circle. Give the domain and range.

(a)

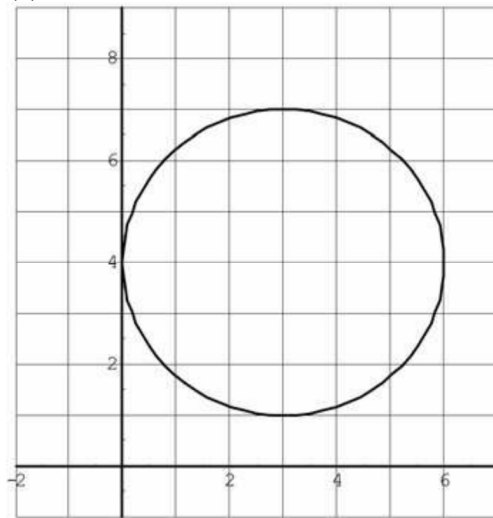

(b)

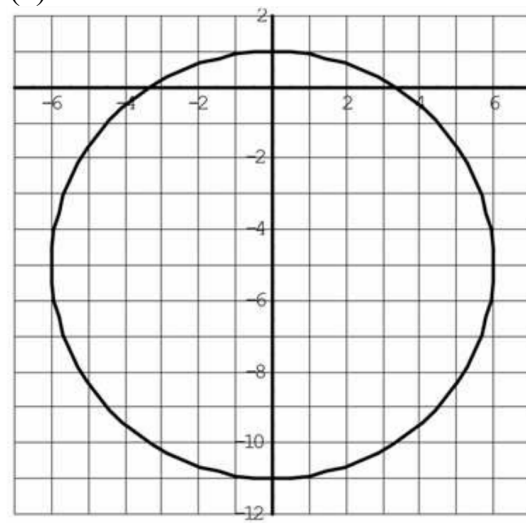

17. For each of the following, sketch the graph of the circle. State the center, radius, domain, and range.

(a)  $(x - 2)^2 + y^2 = 64$

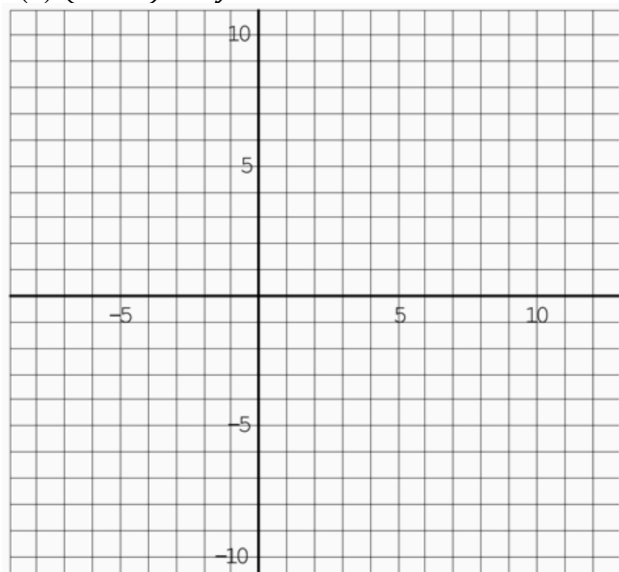

(b)  $(x + 5)^2 + (y - 3)^2 = 49$

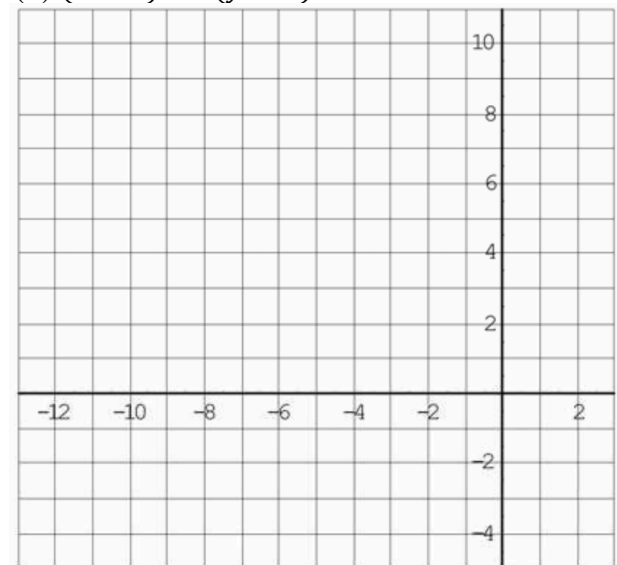

18. A **tangent line** is a line that touches a curve at a single point. If a particular circle whose center is  $(-4, -8)$  is tangent to the  $x$ -axis, what is the standard equation of this circle? What is the general equation? What is the domain and range?

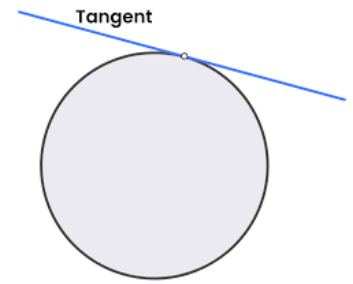

19. A circle has its center on the line with equation  $y = 2x$ . The circle passes through the point  $(1, -3)$  and has a radius of  $\sqrt{5}$  units. Write an equation of the circle in either standard or general form.
20. (Calculator permitted) Since a circle is not the graph of a function, you cannot enter its equation directly into a graphing calculator. Instead, you must solve the equation for  $y$ . The result will contain a  $\pm$  symbol, so you will have two functions.
- (a) Solve  $(x + 3)^2 + y^2 = 16$  for  $y$ .
- (b) What two functions should you enter into the calculator to graph the circle? List each equation separately.
- (c) Graph  $(x + 3)^2 + y^2 = 16$  on your graphing calculator using a Square window (Zoom, #5).
- (d) Now solve  $(x + 3)^2 + y^2 = 16$  for  $x$ . What parts of the circle do the two expressions for  $x$  represent?

***Challenge (not optional):***

Determine the equation of the circle that passes through the points  $(1,7)$ ,  $(-2,-2)$ , and  $(-8,10)$ .